

Digital insulation resistance meter

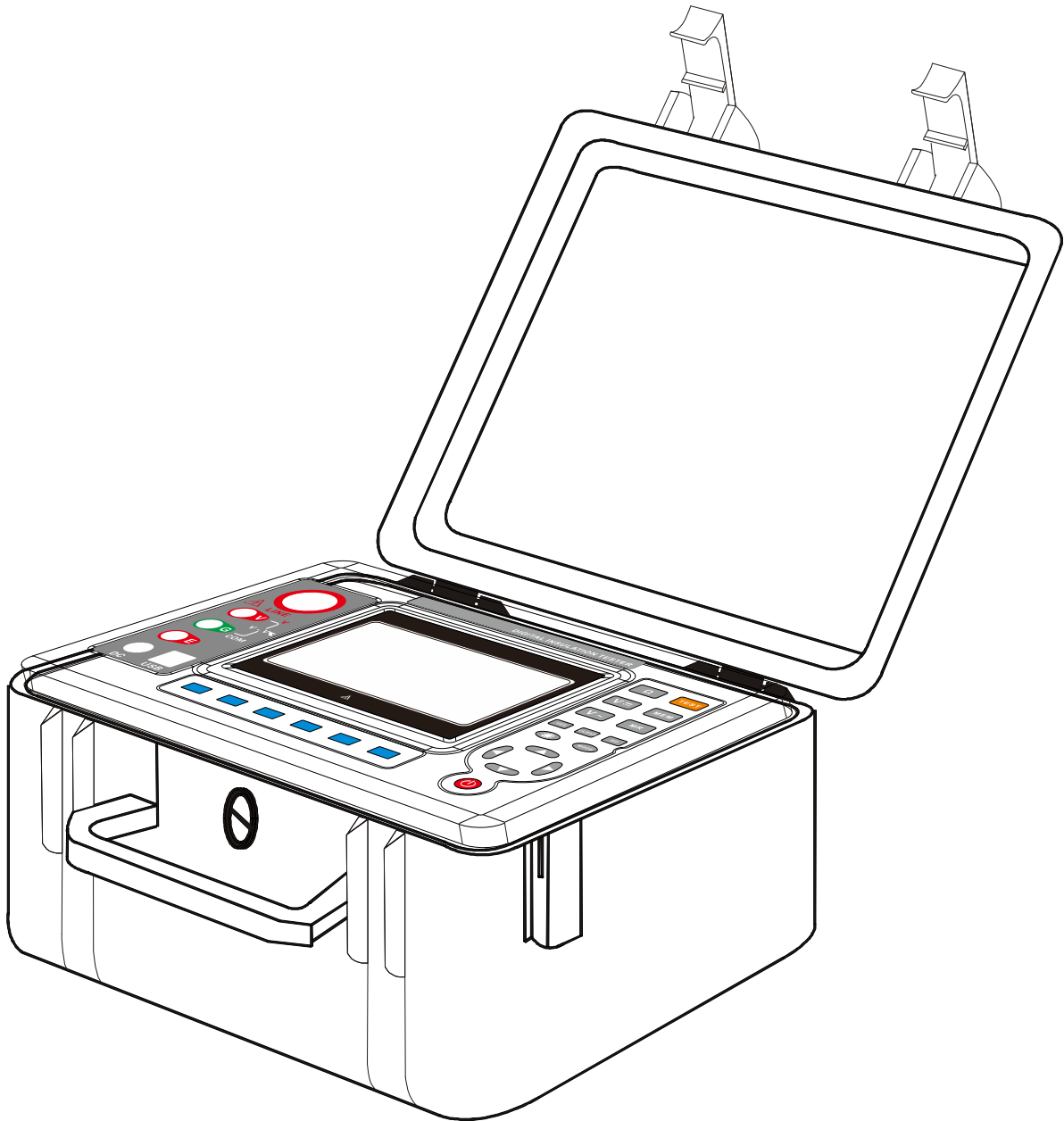

USER MANUAL

Hazari Tech Connect Pvt. Ltd



CONTENT

CONTENT.....	1
I.Safety Rules and Precautions	2
II. Introduction.....	3
III. Range & accuracy.....	4
1. Insulation Resistance Range andAccuracy (notice: The test time of the last two test ranges of each voltage range is greater than 180s)	4
2. Voltage range & accuracy	5
3. Current range & accuracy	5
4. Capacitance range & accuracy.....	6
IV .Technical Specifications	6
V. Structure	9
VI.Measuring Principle.....	10
VII.Operation Method.....	10
1. Power On/Off.....	10
2. Battery Voltage Check.....	11
3. DC Voltage Test.....	11
4. AC Voltage Test.....	11
5. DC Current Test.....	12
6. Capacitance Test	12
7. Insulation Resistance Test	14
8. GUARD Use of Protective Wires	16
9. Polarization Index (PI) and Absorption ratio(DAR).....	17
◆ 9.1 The function of Polarization index (PI) and Absorption ratio(DAR):	17
◆ 9.2 The difference between Polarization index (PI) and Absorption ratio(DAR):	17
◆ 9.3 Polarization index (PI) and Absorption ratio(DAR) Test	18
◆ 9.4Polarization Index (PI) and Absorption Ratio (DAR) Applications:	19
10. Backlight Control.....	20
11. Alarm Value Settings	20
12. Data Lock/Storage	21
13. Data Review/Deletion	21
14. Step Adjustment Resistance Measurement Voltage	22
VIII. Battery Description.....	22

I.Safety Rules and Precautions

Thank you for purchasing our company's **digital high-voltage insulation resistance meter**. Before you use this instrument for the first time, in order to avoid possible electric shock or personal injury, please be **sure to read and strictly observe the safety rules and precautions listed in this manual** . .

In any case, the use of this instrument should pay special attention to safety.

- ◆ The tester is conforming to IEC61010 on design, production and test.
- ◆ Under any circumstance, it shall pay special attention on safety in use of this tester.
- ◆ Please don't use high-frequency signal generators like mobile phone and etc. to avoid error during measuring.
- ◆ Pay attention to words and symbols stick on the Tester.
- ◆ It shall make sure that tester and accessories are in good condition before use; it can be used only when there is no damaged, naked or broken part in testing wires or insulation layer.
- ◆ During measurement, it is forbidden to touch bare conductors and circuit under measurement.
- ◆ Confirm that connector plug of lead has been inserted in the tester interface closely.
- ◆ Please don't impose over 600V A.C. or D.C. voltage on the part between testing end and interface. Otherwise, it may have damage on the tester.
- ◆ Please don't measure in an inflammable place. The flame sparkle maybe cause explosion.
- ◆ During usage of tester, please stop using it when exposed metal is caused by broken enclosure or testing wires.
- ◆ Please don't keep or store the tester in the spot with high-temperature and moisture, or condensation, and under direct daylight radiation for a long time.
- ◆ When the meter displays battery low voltage symbol“  should charge in time, otherwise it will lead to ground error.
- ◆ Do not charge or perform data transmission during the measurement process.
- ◆ Pay attention to measuring range and usage environment stipulated for the Tester.
- ◆ This measuring device is only to be used, disassembled, adjusted and repaired by qualified personnel with authorization.
- ◆ When it may cause hazard by continuous use for the reason of the Tester itself, it shall immediately stop using it and deposit it at once, leaving it for disposal by authorized agency.
- ◆ For risk of danger icon in manual ”, users must perform safety operations strictly in compliance with the manual content.
- ◆ The instrument output high voltage, please be sure to connect the test line hand to leave the test line before pressing the test button to test, otherwise there is

danger of electric shock.

- ◆ After the test is completed, wait for one minute for the discharge to complete before removing the test line. When removing the test line, first remove the test line of the meter and then collect the test line.

II. Introduction

ES3045 series

Digital insulation resistance meter also known as **mega ohmmeter**, **high voltage insulation resistance tester**, etc., for the insulation resistance test. The instrument has a large LCD screen gray backlit display, data storage, data access, alarm, automatic shutdown and other functions. At the same time, it also has the function of measuring DC voltage, AC voltage, absorption ratio and polarization index of DC voltage. The machine is beautiful and upscale, has a wide range, high resolution, convenient operation, easy to carry, accurate, reliable, stable performance, strong anti-interference ability. Moreover, it has a shockproof, dustproof, moisture-proof structure and is a commonly used and indispensable instrument for telecommunications, electricity, meteorology, computer rooms, oil fields, electromechanical installation and maintenance, and industrial enterprises that use electricity as industrial power or energy. It is suitable for measuring the resistance value of various insulating materials and the insulation resistance of transformers, motors, cables and electrical equipment. At the same time, it can output a variety of different voltage levels with the step-adjusting voltage function (for example, 15KV models can generate 12KV levels, which can be used more widely).

Digital insulation resistance meter consists of medium and large scale integrated circuits. The output power of the watch is large, and the output voltage level is a lot (with 6 voltage levels). DC voltage measurement range is 0 ~ 1000V, AC voltage measurement range is 0 ~ 750V. DC current measurement range is 100pA-6mA. Capacitance measurement range is 10nF-50nF.

III. Range & accuracy

1. Insulation Resistance Range and Accuracy (notice: The test time of the last two test ranges of each voltage range is greater than 180s)

Measuring function	Output voltage	Measuring range	accuracy	resolution
Insulation resistance	100V($\pm 10\%$)	0M Ω ~0.5M Ω	$\pm 5\%$ rdg ± 5 dgt	0.001M Ω
		0.5M Ω ~5M Ω	$\pm 5\%$ rdg ± 5 dgt	0.01M Ω
		5M Ω ~0M Ω	$\pm 5\%$ rdg ± 5 dgt	0.1M Ω
		50M Ω ~500M Ω	$\pm 5\%$ rdg ± 5 dgt	1M Ω
		0.5G Ω ~5G Ω	$\pm 5\%$ rdg ± 5 dgt	0.01G Ω
		5G Ω ~50G Ω	$\pm 10\%$ rdg ± 5 dgt	0.1G Ω
		50G Ω ~500G Ω	$\pm 20\%$ rdg ± 5 dgt	1G Ω
	250V($\pm 10\%$)	0 M Ω ~1M Ω	$\pm 5\%$ rdg ± 5 dgt	0.001M Ω
		1 M Ω ~10M Ω	$\pm 5\%$ rdg ± 5 dgt	0.01M Ω
		10 M Ω ~100M Ω	$\pm 5\%$ rdg ± 5 dgt	0.1M Ω
		100M Ω ~1000M Ω	$\pm 5\%$ rdg ± 5 dgt	$\pm 5\%$ rdg ± 3 dgt 1M Ω
		1G Ω ~10G Ω	$\pm 5\%$ rdg ± 5 dgt	0.01G Ω
		10G Ω ~100G Ω	$\pm 10\%$ rdg ± 5 dgt	0.1G Ω
		100G Ω ~1000G Ω	$\pm 20\%$ rdg ± 5 dgt	1G Ω
	500V($\pm 10\%$)	0 M Ω ~2M Ω	$\pm 5\%$ rdg ± 5 dgt	0.001M Ω
		2 M Ω ~20M Ω	$\pm 5\%$ rdg ± 5 dgt	0.01M Ω
		20 M Ω ~200M Ω	$\pm 5\%$ rdg ± 5 dgt	0.1M Ω
		200 M Ω ~2000M Ω	$\pm 5\%$ rdg ± 5 dgt	1M Ω
		2G Ω ~20G Ω	$\pm 5\%$ rdg ± 5 dgt	0.01G Ω
		20G Ω ~200G Ω	$\pm 10\%$ rdg ± 5 dgt	0.1G Ω
		200G Ω ~2000G Ω	$\pm 20\%$ rdg ± 5 dgt	1G Ω
	1000V($\pm 10\%$)	0 M Ω ~5M Ω	$\pm 5\%$ rdg ± 5 dgt	0.001M Ω
		5 M Ω ~50M Ω	$\pm 5\%$ rdg ± 5 dgt	0.01M Ω
		50 M Ω ~500M Ω	$\pm 5\%$ rdg ± 5 dgt	0.1M Ω
		500 M Ω ~5000M Ω	$\pm 5\%$ rdg ± 5 dgt	1M Ω
		5G Ω ~50G Ω	$\pm 10\%$ rdg ± 5 dgt	0.01G Ω
		50G Ω ~500G Ω	$\pm 15\%$ rdg ± 5 dgt	0.1G Ω
		500G Ω ~5000G Ω	$\pm 20\%$ rdg ± 5 dgt	1G Ω
	2500V($\pm 10\%$)	0 M Ω ~10M Ω	$\pm 5\%$ rdg ± 5 dgt	0.01M Ω
		10 M Ω ~100M Ω	$\pm 5\%$ rdg ± 5 dgt	0.1M Ω
100 M Ω ~1000M Ω		$\pm 5\%$ rdg ± 5 dgt	1M Ω	
1 G Ω ~10G Ω		$\pm 5\%$ rdg ± 5 dgt	0.01G Ω	
10 G Ω ~100G Ω		$\pm 10\%$ rdg ± 5 dgt	0.1G Ω	
100 G Ω ~1000G Ω		$\pm 15\%$ rdg ± 5 dgt	1G Ω	
1 T Ω ~10T Ω		$\pm 20\%$ rdg ± 10 dgt	0.01T Ω	

	5000V($\pm 10\%$)	0 M Ω ~20M Ω	$\pm 5\%$ rdg ± 5 dgt	0.01M Ω
		20 M Ω ~200M Ω	$\pm 5\%$ rdg ± 5 dgt	0.1M Ω
		200 M Ω ~2000M Ω	$\pm 5\%$ rdg ± 5 dgt	1M Ω
		2 G Ω ~20G Ω	$\pm 5\%$ rdg ± 5 dgt	0.01G Ω
		20 G Ω ~200G Ω	$\pm 10\%$ rdg ± 5 dgt	0.1G Ω
		200 G Ω ~2000G Ω	$\pm 15\%$ rdg ± 5 dgt	1G Ω
		2 T Ω ~10T Ω	$\pm 25\%$ rdg ± 10 dgt	0.01T Ω
	10KV($\pm 10\%$)	0 M Ω ~50M Ω	$\pm 5\%$ rdg ± 5 dgt	0.01M Ω
		50 M Ω ~500M Ω	$\pm 5\%$ rdg ± 5 dgt	0.1M Ω
		500 M Ω ~5000M Ω	$\pm 5\%$ rdg ± 5 dgt	1M Ω
		5 G Ω ~50G Ω	$\pm 5\%$ rdg ± 5 dgt	0.01G Ω
		50 G Ω ~500G Ω	$\pm 10\%$ rdg ± 5 dgt	0.1G Ω
		500 G Ω ~5000G Ω	$\pm 20\%$ rdg ± 5 dgt	1G Ω
		5T Ω ~35T Ω	$\pm 35\%$ rdg ± 10 dgt	0.01T Ω
	15KV($\pm 10\%$)	0 M Ω ~60M Ω	$\pm 5\%$ rdg ± 5 dgt	0.01M Ω
		60 M Ω ~600M Ω	$\pm 5\%$ rdg ± 5 dgt	0.1M Ω
		600 M Ω ~6000M Ω	$\pm 5\%$ rdg ± 5 dgt	1M Ω
		6 G Ω ~60G Ω	$\pm 5\%$ rdg ± 5 dgt	0.01G Ω
		60 G Ω ~600G Ω	$\pm 10\%$ rdg ± 5 dgt	0.1G Ω
		600 G Ω ~6000G Ω	$\pm 20\%$ rdg ± 5 dgt	1G Ω
		6 T Ω ~50T Ω	$\pm 35\%$ rdg ± 10 dgt	0.01T Ω

Remark: Common electrical unit conversion

1 T Ω (Tera ohm) =1000G Ω =10¹² Ω

1 G Ω (Giga ohm) =1000M Ω =10⁹ Ω

1 M Ω (Mega ohm) =1000K Ω =10⁶ Ω

2. Voltage range & accuracy

Measuring function	Measuring range	accuracy	resolution
DC voltage	DC 0.0V~1000V	$\pm 5\%$ rdg ± 3 dgt	0.1V
AC voltage	AC 0.0V~750V	$\pm 5\%$ rdg ± 3 dgt	0.1V

3. Current range & accuracy

Measuring function	Measuring range	accuracy	resolution
DC current	1mA-6mA	$\pm 10\%$ rdg ± 5 dgt	0.01mA
	100uA-1000uA	$\pm 10\%$ rdg ± 5 dgt	1uA
	10uA-100uA	$\pm 10\%$ rdg ± 5 dgt	0.1uA
	1uA-10uA	$\pm 10\%$ rdg ± 5 dgt	0.01uA
	100nA-1000nA	$\pm 10\%$ rdg ± 5 dgt	1nA

	10nA-100nA	$\pm 20\% \text{rdg} \pm 5 \text{dgt}$	0.1nA
	1nA-10nA	$\pm 20\% \text{rdg} \pm 5 \text{dgt}$	0.01nA
	100pA-1000pA	$\pm 30\% \text{rdg} \pm 5 \text{dgt}$	1pA

4. Capacitance range & accuracy

Measuring function	Measuring range	accuracy	resolution
capacitance	10uf-50uf	$\pm 15\% \text{rdg} \pm 5 \text{dgt}$	0.01uf
	1uf-10uf	$\pm 15\% \text{rdg} \pm 5 \text{dgt}$	0.1uf
	100nf-10nf	$\pm 15\% \text{rdg} \pm 5 \text{dgt}$	0.01nf
	10nf-100nf	$\pm 15\% \text{rdg} \pm 5 \text{dgt}$	0.01nf

IV .Technical Specifications

Function		Insulation resistance test, voltage test, DC current test, capacitance test	
Basic condition		23°C \pm 5°C, below 75%rh	
8250IN	Rated voltage	100V、250V、500V、1000V、2500V、5000V	
	Insulation resistance range	0.01M Ω ~10T Ω	resolution: 0.01M Ω
8251IN	Rated voltage	250V、500V、1000V、2500V、5000V、10KV	
	Insulation resistance range	0.01M Ω ~35T Ω	resolution: 0.01M Ω
8252IN	Rated voltage	500V、1000V、2500V、5000V、10KV、15KV	
	Insulation resistance	0.01M Ω ~50T Ω	resolution: 0.01M Ω

	range		
Test Voltage(V)		rated voltage× (1±10%)	
DC Voltage Range	0~1000V	Resolution: 0.1V	
AC Voltage Range	0~750V	Resolution: 0.1V	
DC Current	0.1nA~6mA	Resolution: 0.1nA	
Capacitance	10nF~50uF	Resolution: 10nF	
Output short-circuit Current	≥6mA		
Absorption Ratio and Polarization Index Measurement	Have		
Power Supply	12V rechargeable battery		
Backlight	Controllable gray screen backlight, suitable for use in dim places		
Display mode	4-bit large LCD display, gray screen backlight		
LCD display size	108mm×65mm		
Instrument size	L/W/H: 240mm×188mm×85mm		
USB interface	With USB interface, software monitoring, storage data can be uploaded to the computer, save and print		
Communication Line	USB communication line 1PC		
Test Line	High voltage red 3meter, high voltage test line black 1.5meter, green 1.5meter		
Data Storage	500 groups, "FULL" symbol indicates that storage is		

	full
Data Review	Data review function: "MR" symbol display
Overflow Display	Exceed measurement range overflow function: "> " symbol display
Alarm Function	Alarm when the measured value larger or smaller than the alarm setting value
Power Consumption	Standby: 30mA Max(backlight off), Turn on backlight: 42mA Max Measure: 300mA Max(backlight off)
Instrument weight	2750g(including battery)
Battery voltage	When the battery voltage is low, low battery symbol "  'will display
Automatic shut-down	automatic shutdown after 15 minutes boot
Insulation Resistance	≥50MΩ(between Measuring line and housing)
Pressure Resistance	AC3kV/50Hz 1min
Working Temperature and Humidity	−10°C~+50°C<85%RH
Storage Temperature and Humidity	−15°C~+55°C<90%RH
Suitable for Safety Regulations	IEC61010-1,IEC1010-2-31,IEC61557-1,5,IEC60529(IP54),pollution grade 2,CAT IV 600V

V. Structure

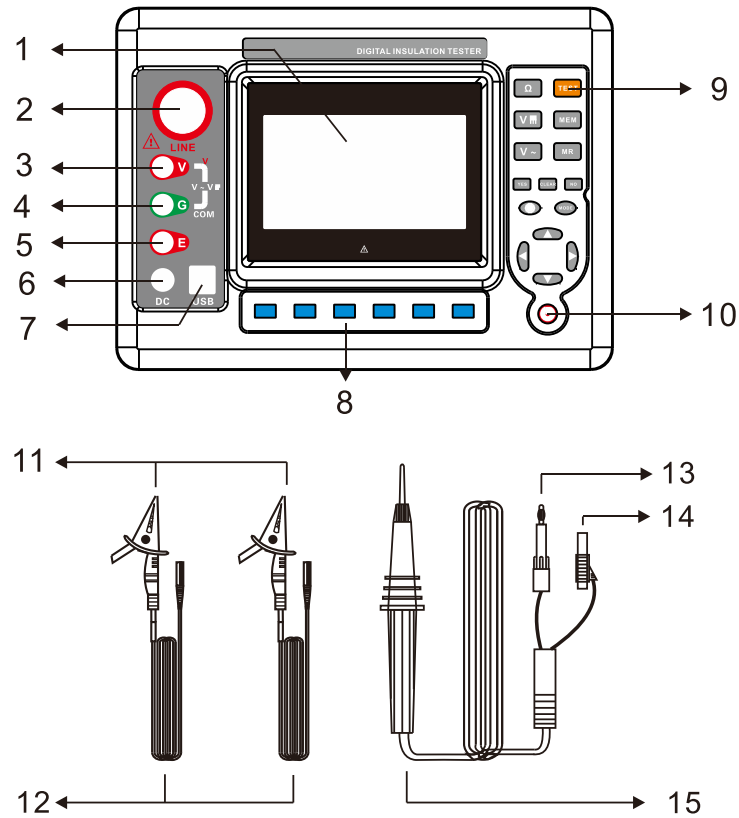

- | | | |
|---|------------------------------------|-----------------------------|
| 1. LCD display screen | 2. LINE interface | 3. V interface |
| 4. GUARD interface | 5. EARTH interface | 6. changer interface |
| 7.USB interface | 8. Voltage select button | 9. Test button |
| 10. Power on/off button | 11. Security Alligator Clip | |
| 12. Test line (green , black each 1PC) | | |
| 13. High voltage test terminal banana plug into LINE interface | | |
| 14. Shielded cable connector plugged into GUARD interface (no connection) | | |

required without this connector)
15.High voltage test line

VI.Measuring Principle

Insulation resistance measurement uses a voltage generator to generate a voltage, **V**, applied across the resistor, measuring the current **I** flowing across the resistor, and calculating the ground resistance value **R** according to the formula $R=V/I$.

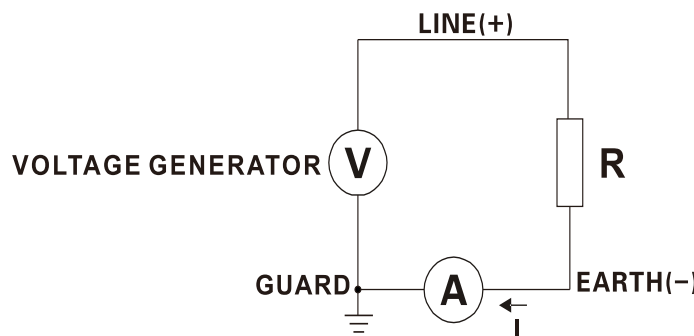

$$R = V / I$$

VII.Operation Method

1. Power On/Off

Press the POWER button to turn the switch on and off. After the power is turned on, "APO" is displayed in the lower corner. When it is not in operation, it will automatically shut down after 15 minutes.

2. Battery Voltage Check

After powering on, if the LCD shows a low battery voltage sign “”, it indicates that the battery is running low. Please charge in time. Sufficient battery power to ensure measurement accuracy

3. DC Voltage Test

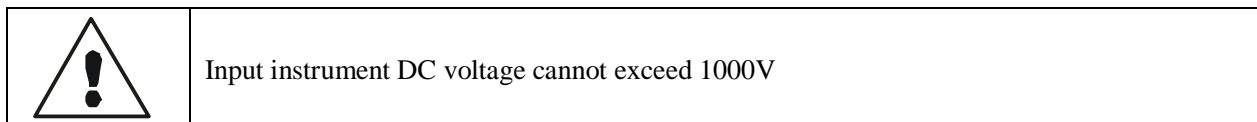

When measuring, turn the rotary switch to the gear  to switch to the DC voltage test mode, connect the green test lead to the V terminal, the black test lead to the COM, and the LCD displays the real-time DC voltage value.

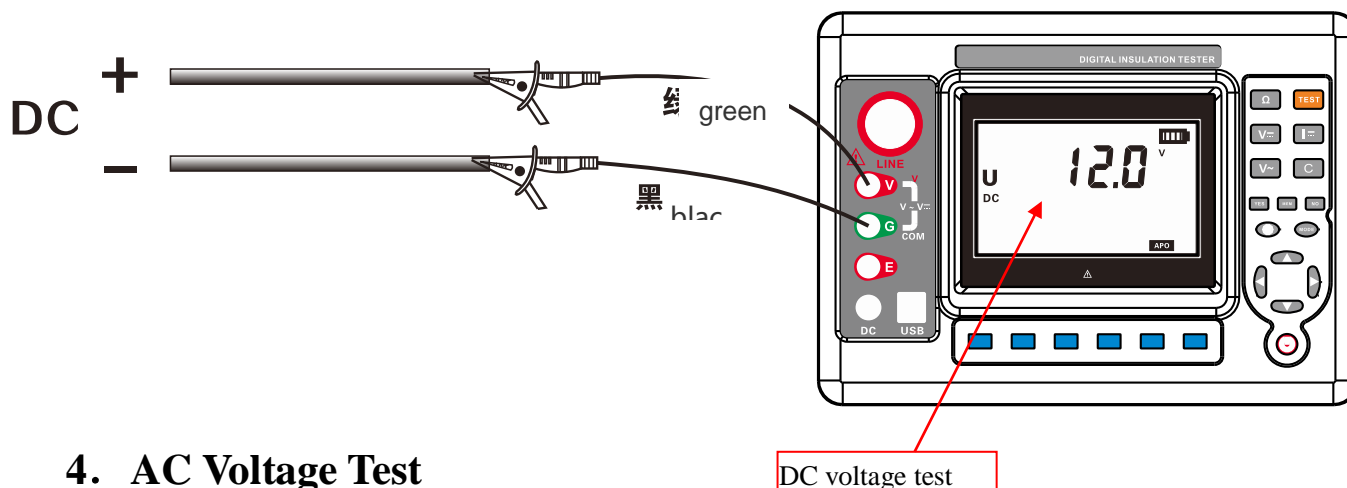

4. AC Voltage Test

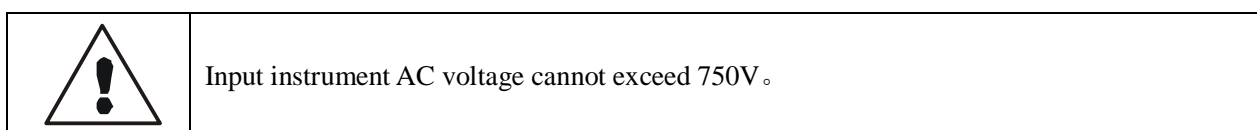

When measuring, turn the rotary switch to the gear  position to switch to AC voltage test mode., connect the green lead to the V terminal, the black lead to the COM, and the LCD displays the real-time AC voltage value.

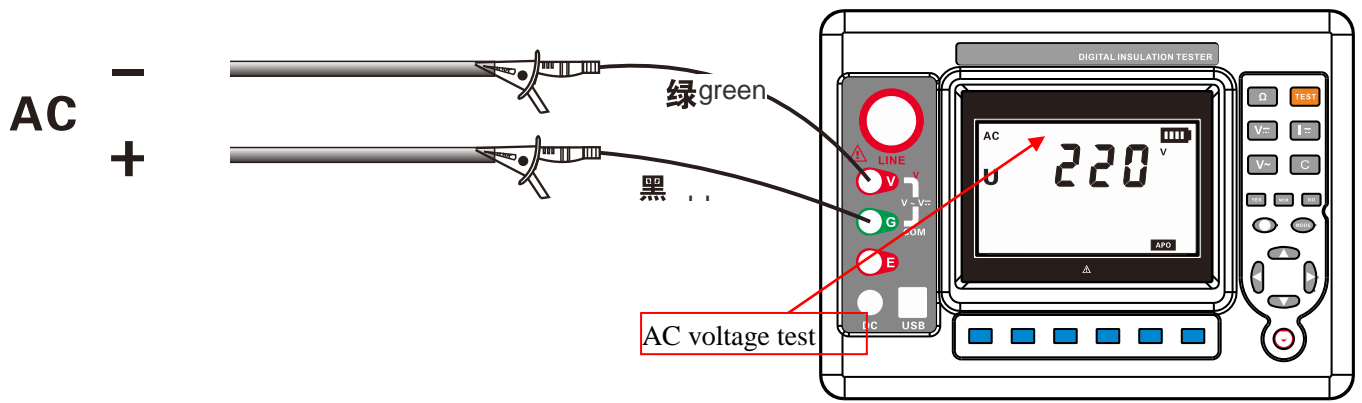

5. DC Current Test

1. When measuring, turn the rotary switch to the gear  position to switch to DC current test mode., connect the green lead to the E terminal, the black lead to the COM, and the LCD displays the real-time current value.

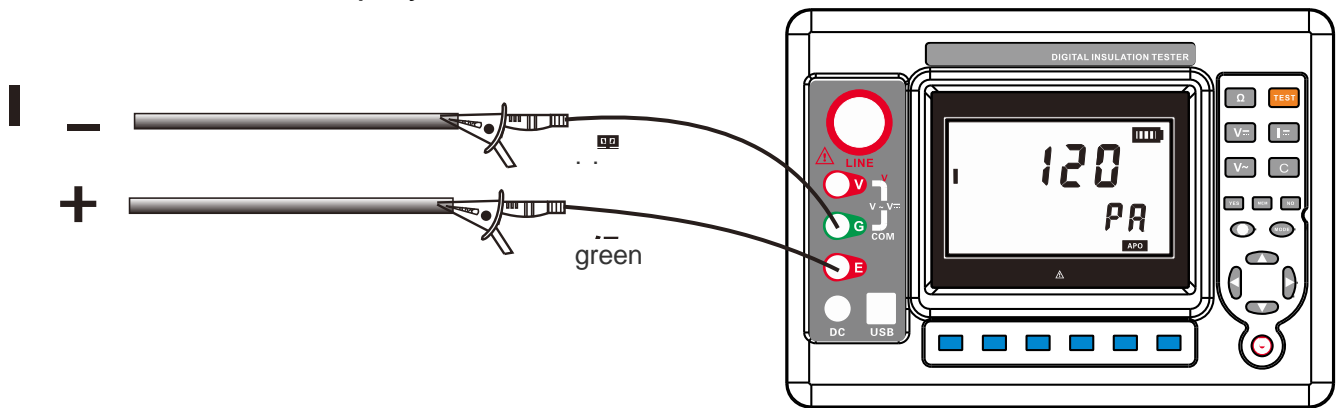

2. During the current test, the units of mA are shown in Figure 5-2, and the units of nA, uA, and pA are shown in Figure 5-1.



Figure 5-1 Test process display

Current unit nA



Figure 5-2 Test process display

Current unit mA

6. Capacitance Test

1. Capacitance test DC voltage 300V ($\pm 10\%$) 。

2. When measuring, press the button  to switch to the capacitance test mode. One end of the high-voltage rod test lead (red) is connected to the meter **LINE** and the other end of the head is in contact with the capacitor under test. One end is connected to COM and the other end is connected to the capacitor.

Press the test key **TEST** to start the test (the meter will emit an intermittent beep: the prompt sound of "drop ~ drop ~ drop ..." during the test). After the test is completed, the LCD displays the correct capacitance value. **Note: Pay attention to the standard operation during the capacitance test. Manually discharge after each test. Do not touch the capacitor by hand without discharging.**

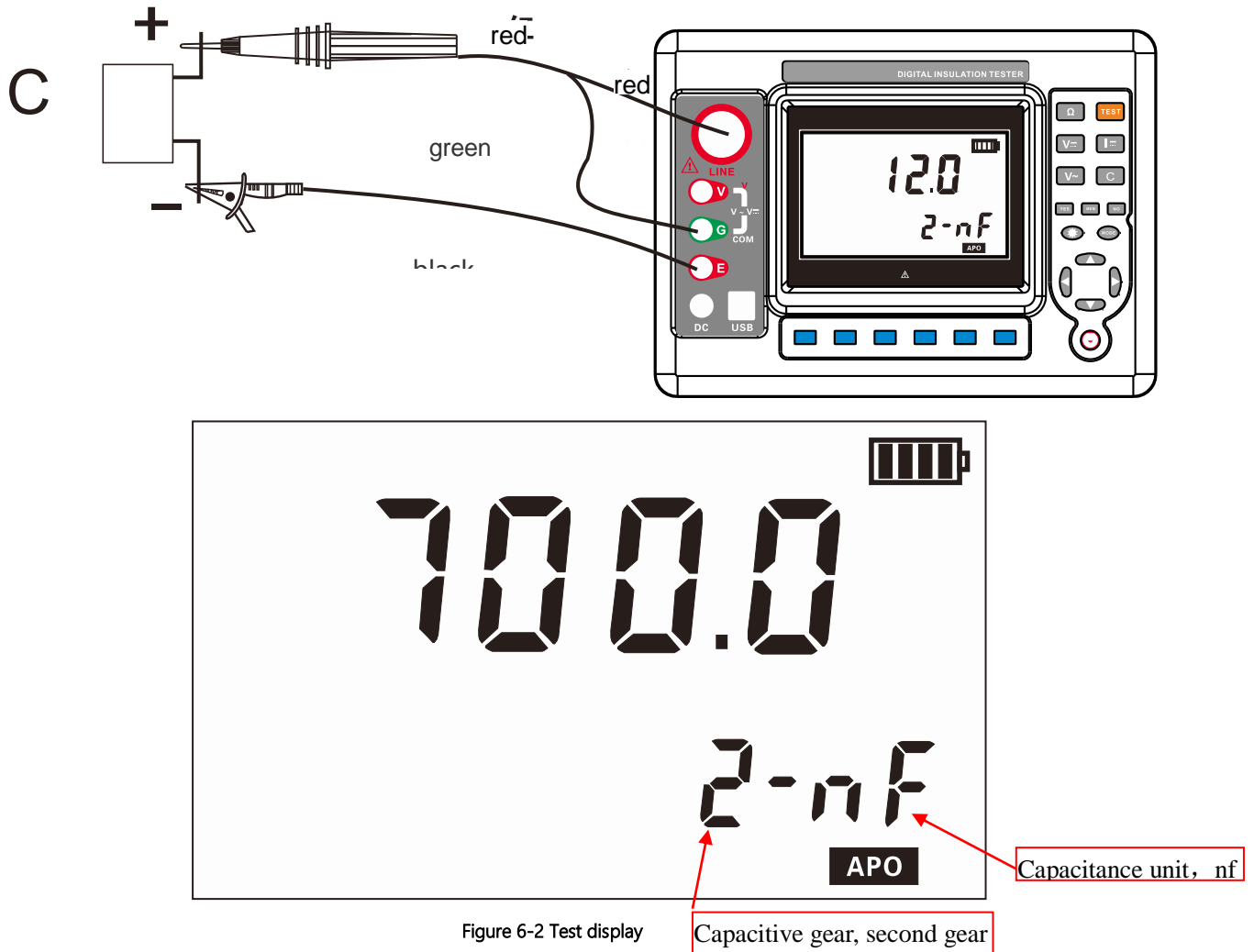

Figure 6-2 Test display



3. The capacitance measurement mode has 4 gears and requires manual shift testing. The first range is 10nf-100nf, the second range is 100nf-1000nf, the third range is 1uf-10uf, and the fourth range is 10uf-50uf. During the test, the value greater than or less than a certain value needs to be manually switched to the corresponding gear. The gear can be switched by pressing the  (gear minus 1) or  (gear plus 1) button.



Figure 6-3 Test completed less than

Less than changeable gears smaller than the current gear

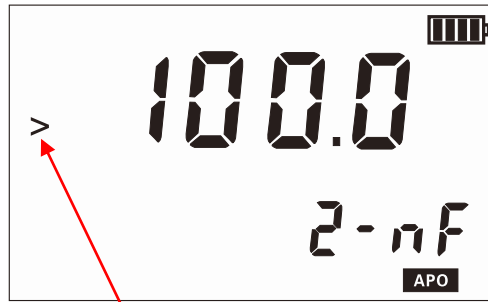



Figure 6-3 Test completed larger than

larger than changeable gears larger than the current gear

7. Insulation Resistance Test

	<p>Insulation resistance test can only be carried out on an uncharged circuit. Before testing, check whether the test circuit wiring is in good condition and whether the circuit under test is energized. If the circuit is live, it may damage the instrument and affect the measurement accuracy.</p>
	<p>Must wear high-voltage insulating gloves to operate.</p>
	<p>In the insulation resistance range, press the test switch to generate high voltage in the test line head and in the circuit under test. Please be careful to avoid touching.</p>
	<p>Be sure to connect the grounding wire (black) to the grounding port of the circuit under test.</p>
	<p>Do not touch the circuit immediately after testing. The stored charge may cause electric shock.</p>
	<p>Do not remove the test lead immediately. Wait until the discharge is complete before touching the circuit under test.</p>
	<p>In order to ensure the measurement accuracy, do not twist the test lines together.</p>

i. Precautions for testing high insulation resistance

1. After the high-voltage insulation material is added with DC voltage, the current passing through the sample is very small, and it is very susceptible to the influence of external interference, causing large test errors.
2. The higher the measured resistance value, the longer the measurement time.
3. As humidity increases, surface leakage increases, and bulk electrical current also increases.
4. The resistance value of general materials decreases with the increase of ambient temperature and humidity.

ii. Guaranteed temperature and humidity of the insulation resistance accuracy

Insulation resistance range	Guaranteed the humidity value of the insulation resistance accuracy	Guaranteed temperature of the insulation resistance accuracy
0Ω-100MΩ	<85% RH(No condensation)	23°C±5°C
100MΩ-20GΩ	<75% RH(No condensation)	
20GΩ-1000GΩ	<65% RH(No condensation)	
1000GΩ-1TΩ	<55% RH(No condensation)	

1TΩ-10TΩ	<45% condensation)	RH(No	
10TΩ-50TΩ	<35% condensation)	RH(No	

1. Insulation resistance test can only be carried out on an uncharged circuit. Before testing, check that the test leads are good and confirm that the circuit under test is uncharged.

2. Turn the rotary switch to Ω gear to switch to resistance test mode, then press **100V** or **250V** or **500V** or **1000V** or **2500V** or **5000V** or **10KV** or **15KV** button to select the voltage value to be tested.

3. One end of the ground wire (black) is connected to the instrument connection **EARTH** and the other end is connected to the ground end of the circuit under test. One end of the high-voltage rod test line (red) is connected to the other end of the instrument **LINE** and the head is in contact with the circuit under test. If the test has a green branch line as a shielded line, the accuracy of connecting the **GUARD** port during testing is better (**Testing resistance above TΩ must be connected with green shielded wire**). If the matching test line does not carry this line, it does not need to be connected. As shown in the figure, press the **TEST** test button (During the test, the meter will emit an intermittent beep: "Drip ~ Drop ~ Drop..." Flashing **TEST** in the lower left corner of the screen). The LCD shows the measured value. Read the insulation resistance value after the measured value is fixed. After the resistance test is completed, press and hold the Ω key to switch the displayed current value, and then press the Ω key to switch back to the resistance value.

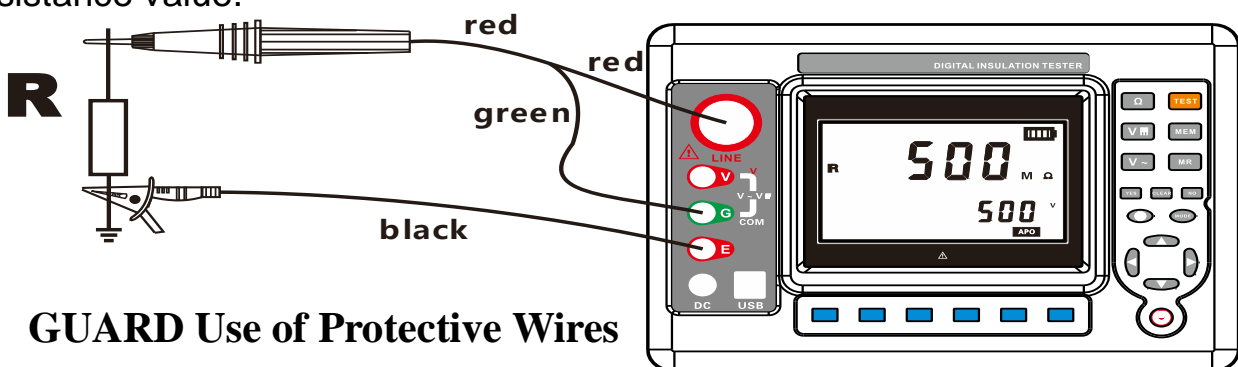

8. GUARD Use of Protective Wires

When the insulation resistance of the cable is measured, the leakage current of the covered surface passes through the interior of the insulator and the current converges, resulting in an error in the insulation resistance value. In order to avoid this phenomenon, as shown in the figure below, use the protection wire (any conductive bare wire) to flow the leakage current through the part. After connecting to the protection port, the leakage current does not flow through the indicator and the insulator can accurately measure the insulation resistance. Please use the

protection test cable of the accessory to connect the protection port.

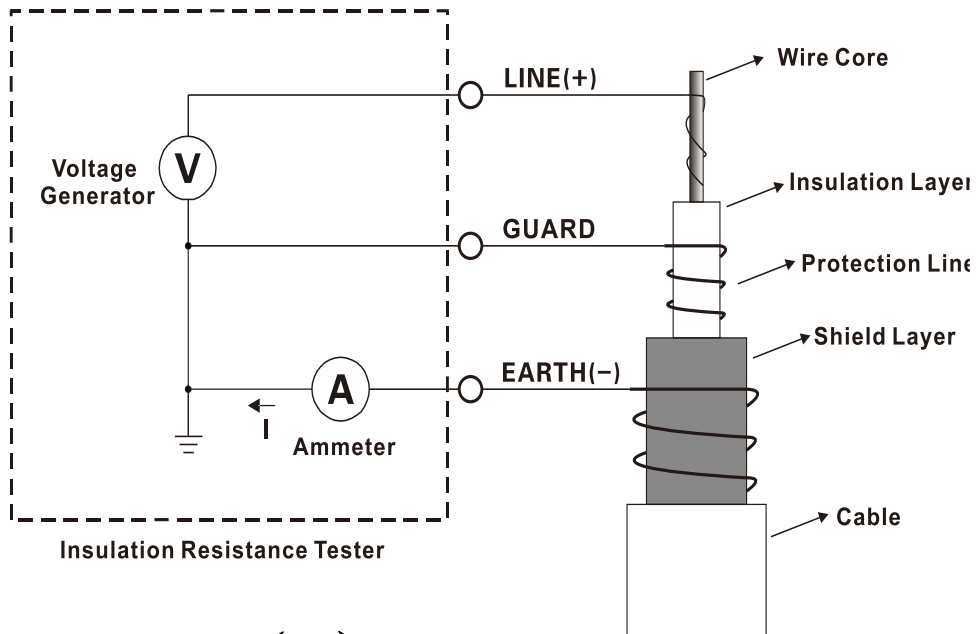

9. Polarization Index (PI) and Absorption ratio(DAR)

◆ 9.1 The function of Polarization index (PI) and Absorption ratio(DAR):

The Polarization Index (PI) and Absorption Ratio (DAR) are tests to check whether the leakage current of the insulator has increased. The leak current did not increase while confirming the application time. The instrument automatically calculates the polarization index PI and the absorption ratio DAR. As a judgement of the insulation performance, both the polarization index PI and the absorption ratio DAR indicate the change in the insulation resistance over a period of time after the measured object withstands the measured voltage.

◆ 9.2 The difference between Polarization index (PI) and Absorption ratio(DAR):

For general insulation tests, such as housing insulation, tool handles, etc. can generally be tested in a relatively short period of time to increase the leakage current with the increase of the voltage application time, so generally can be tested with a short time test, the short-term insulation resistance ratio DAR is called the absorption ratio (see the following formula for the specific test time), but for the large-capacity and long-term absorption process, such as transformers, generators, cables, capacitors and other electrical equipment, sometimes the absorption ratio (DAR) is not enough to reflect the whole process of absorption, and the insulation resistance ratio can be used for a longer time, that is, the ratio between the insulation resistance (R10min) at 10 minutes and the insulation resistance (R1min) at 1 minute describes the entire process of insulation absorption, and PI is called the polarization index.

The PI and DAR values are calculated by the following formula:

$$\text{PI(Polarization Index)} = \frac{R10Min}{R1Min}$$

$$\text{DAR (Absorption ratio)} = \frac{R_{60\text{Sec}}}{R_{15\text{Sec}}}$$

$$\text{DAR (Absorption ratio)} = \frac{R_{60\text{Sec}}}{R_{30\text{Sec}}}$$

- Remark:**
- 1: R10Min= resistance value measured by the voltage applied for 10 minutes
 - 2: R1Min=R60Sec=the resistance value measured by the voltage applied for 1 minutes
 - 3 : R30Sec=It is the resistance value measured by the voltage applied for 30 seconds
 - 4: R15Sec=It is the resistance value measured by the voltage applied for 15 seconds
 - 5: DAR calculation time can choose 15 seconds or 30 seconds

◆ 9.3 Polarization index (PI) and Absorption ratio(DAR) Test

1.The Polarization Index (PI) and Absorption Ratio Test (DAR) can only be performed on uncharged circuits. Before testing, check that the test leads are good and confirm that the circuit under test is charged or not.

2.Turn the rotary switch to Ω gear, then press **100V** or **250V** or **500V** or **1000V** or **2500V** or **5000V** or **10KV** or **15KV** button to select the voltage value to test.

3. Press the **MODE** key to set the corresponding mode. The LCD shows “10:01m” as the polarization index mode in the lower left corner of the LCD, “60:15S” as the absorption mode 15 second mode, and “60:30S” as the absorption mode 30 second mode. Small numbers do not show anything for the insulation resistance measurement mode.



Figure 9-1 Absorption ratio mode 15 second mode



Figure 9-2 Absorption ratio mode 30 seconds mode



Figure 9-3 Polarization index mode



Figure 9-4 Insulation resistance measurement mode

4.One end of the ground wire (black) is connected to the instrument connection **EARTH** and the other end is connected to the ground end of the circuit under test. One end of the high-pressure rod test line (red) is connected to the other end of the instrument **LINE** and the head is in contact with the circuit under test, and the **TEST** test key is pressed. The LCD displays the measured value. After the measured value is fixed, the absorbance or polarization index can be read



5. After the test is completed, you can press  to switch to view the divisor and ratio of the absorption ratio or polarization index value, or press  to switch to view the ratio or divisor of the absorption ratio or polarization index value. (Such as in "60: 15S" mode, the lower left corner displays "60: 15S" as the ratio, the display "15S" as the dividend, and the display "60S" as the divisor, the other modes are the same)



Figure 9-5 Ratio



Figure 9-6 The dividend

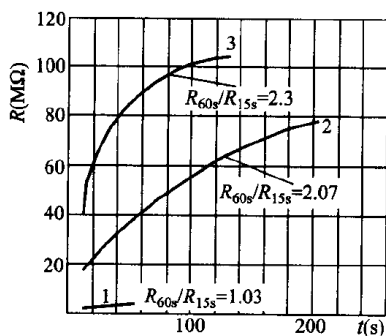

Figure 9-7 Divisor

◆ 9.4 Polarization Index (PI) and Absorption Ratio (DAR) Applications:

In engineering, insulation resistance and absorption ratio (or polarization index) can reflect the degree of moisture in the insulation of generators, oil-immersed power transformers and other equipment. The value of the absorption ratio (or polarization index) decreases after the insulation is wet (see Figure 1), so it is an important indicator of whether the insulation is affected by moisture.

It should be pointed out that sometimes the insulation has obvious defects (for example, the insulation breaks down under high pressure), and the absorption ratio or polarization index value is still good. The absorption ratio or polarization index cannot be used to find other local insulation defects other than moisture and dirt.



1—干 2—When the end of drying, 73.5 degree Celsius; 3—After running 72h, and cooled to 27 degree Celsius

Figure 1 The relationship between the insulation resistance R of a generator and the time t

Polarization Index Reference Judgment Value:

Polarization Index	Above 4	4~2	2.0~1.0	Below 1.0
Judge	The best	Good	Need to pay attention	Bad

Absorption ratio reference judgment value:









Absorption ratio	Above 1.4	1.25~1.0	Below 1.0
------------------	-----------	----------	-----------

10. Backlight Control

After power on, press “  ” key to turn the backlight on or off, and the backlight function is suitable for dim places. The default backlight turns off every time you turn it on.

11. Alarm Value Settings

1. After power on, long press “  ” to turn on and off the alarm function.

2. Long press  key to enter alarm value setting mode, short press  key to select resistance setting, short press  key to select DC voltage setting, short press  key to select AC voltage setting. Then press the  (plus 10) key or  (minus 10) key, or the  key (plus 1) or  (minus 1) key to change the current number size. Finally, press  to save and exit.

3. When the measured voltage value is greater than the alarm critical set value or the insulation resistance value is less than the alarm critical set value and the alarm function is turned on, the instrument flashes the “ ” symbol and issues a “beep-beep-beep--” alarm sound. The maximum value of the DC voltage alarm setting is 900V, the maximum value of the AC voltage alarm setting is 700V, and the maximum value of the insulation resistance alarm setting is 9999MΩ. The following figure shows an example (“<” is less than the symbol to indicate an alarm, and “>” is greater than the symbol to indicate an alarm):



Figure 11-1 Resistance setting interface



Figure 11-2 AC voltage setting interface



Figure 11-3 DC voltage setting

12. Data Lock/Storage

1. After the measurement is completed, press the **MEM** key to lock the currently displayed data, and automatically numbered storage, short press **MEM** key again to exit the lock, if the storage is full, the meter displays the "FULL" symbol.

2. As shown in the following figure: the measured data is 1258m ω , and the "MEM" display is stored as the fifth set of data. As shown in the following figure: the measured data is 1258M Ω , short press **MEM** to display and store as the fifth group of data



Figure 12-1 Lock and save display

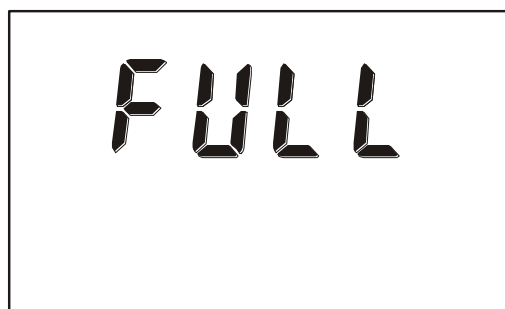

Figure 12-2 Storage full display

lock identifier

Storage index value

13. Data Review/Deletion

1. After booting, if the meter has saved data, long press the **MEM** button to enter the data lookup, and store the data read interface "MR" symbol display. Press the "**▲**" or "**▼**" key check the corresponding data with step value of 10, press the "**◀**" or "**▶**" key to check the corresponding data with a step value of 1, and then short press **MEM** to exit the check.

2. As shown in the figure below: The number 5 in the lower left corner of the screen when checking is the currently stored 5th data. If there is no stored data, the LCD displays "NULL". (The resistance data in the lower right corner shows the voltage, current and capacitance display units used in the test).



Figure 13-1 Resistance check



Figure 13-2 AC voltage check



Figure 13-3 No stored data

Check the index value, the fifth data

Check data identifier



Figure 13-4 DC voltage check

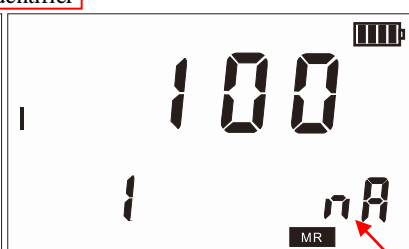

Figure 13-5 Current check

Current unit



Figure 13-6 capacitance check

Capacitance unit











3. In the data review state, long press  key to enter the data deletion, press  key not to delete and return to the data review state, press  key to delete the all the stored data. Delete page as shown below



Figure 13-6 Delete display

14. Step Adjustment Resistance Measurement Voltage

After starting up, you can modify the voltage value by pressing  or  key at a step value of 50V below the 10KV voltage range, or by pressing  or  key at a step value of 5V. For 10KV voltage range and above, you can modify the voltage value by pressing  or  key with a step value of 500V, or press the  or  key with 50V step value to modify the voltage value. **Note:** The maximum voltage does not exceed 15KV, and the step accuracy is $\pm 20\%$.

VIII. Battery Description

1. The meter uses a 12.6V lithium battery for power supply. When the battery power is low, the power symbol " is displayed, please charge it in time. **Note:** When the battery power is low, the measurement accuracy will be affected.
2. The higher the measurement voltage, the higher the battery power requirements.

IX. Accessories

Instrument	1PC
High pressure rod	1PC red
High voltage test	2PCS (black, green each 1)

line	
Monitoring Software CD	1PC
USB communication line USB	1PC
charger	1PC
Manual, certificate	1SET
Instrument box	1PC

The contents of this user manual cannot be used as a reason for using the product for special purposes.
The company is not responsible for other losses caused by use.
The company reserves the right to modify the contents of the user manual. Subject to change without notice.

Hazari Tech Connect Pvt. Ltd.

Hazari House, 197/201 DR. C.H. Street, Dhobi Talao, Mumbai 400 002.

Tel: 022-2201 6969/4962 2004

Mob No. +91-80975 16378/93210 96969

E-mail: sales@hazari.com

WebSite: www.htcinstrument.com